

CONNECT & DISCONNECT INSTRUCTIONS FOR ANSI B29.1 ROLLER CHAINS

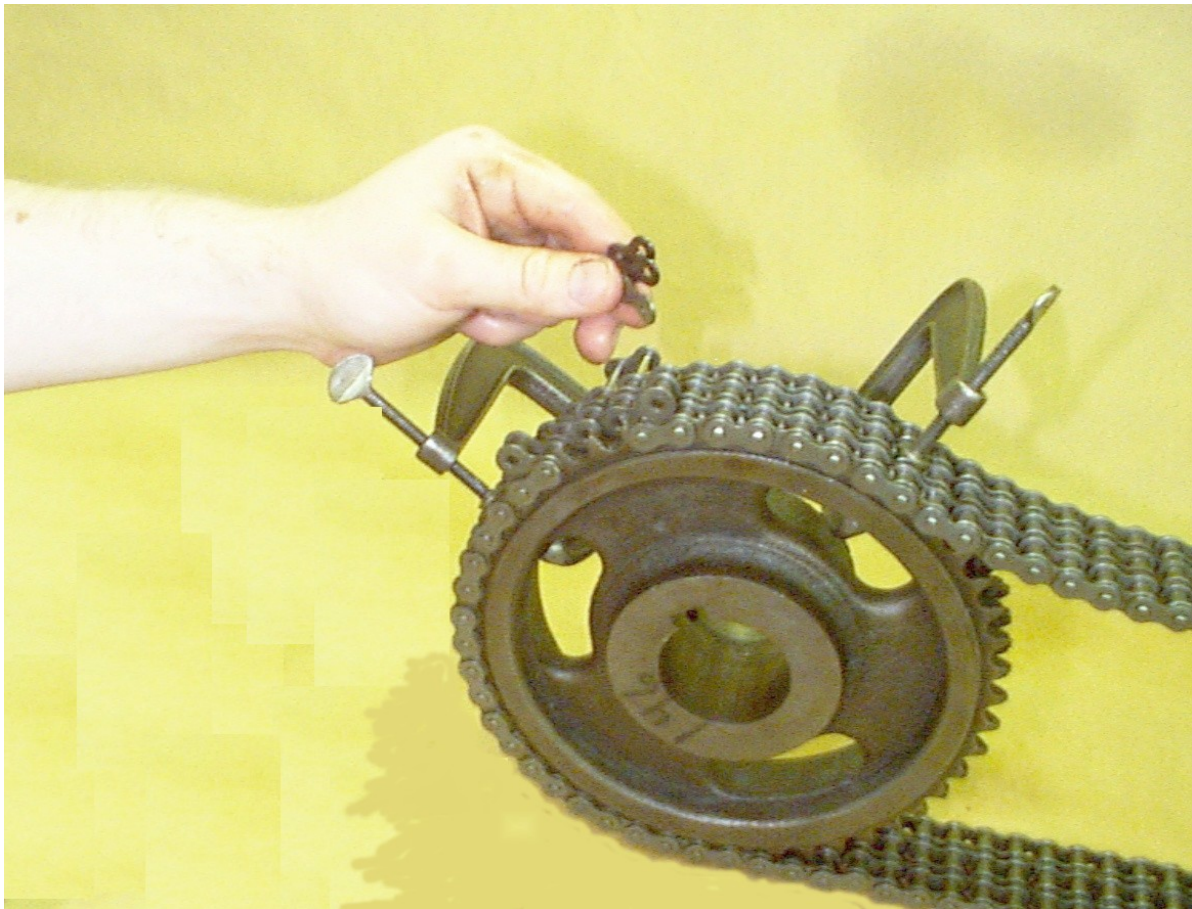

aca

INTRODUCTION

Since roller chain performance is dependent on interference fits of component parts, this Connect-Disconnect instruction has been developed to guide the individual working on the chain in the techniques that are considered by chain manufacturers to be safe while protecting the design integrity of the roller chain.

These instructions, in most cases, are directed to reworking in areas where "Pressing Equipment" is available and therefore all instructions are based on the use of pressing equipment which puts a slow, steady force on the component.

TOOLS AND EQUIPMENT

Tools and equipment should be properly sized to insure safe working conditions and to reduce the possibility of damage to the chain or its components. When connecting/disconnecting chain, pressing equipment is preferred. Also, a chain vice or a similar type of holding device or clamps are recommended to secure and support the chain in place. Please contact the Manufacturer for specific instructions if necessary.

The following are commonly used tools in connecting/disconnecting chain.

1. Pressing Equipment
 - a. Hydraulic chain press
 - b. Jack (mechanical or hydraulic)
 - c. Arbor press
2. Support Fixtures
 - a. Chain vice
 - b. "C" clamps
 - c. Parallel bar spacers, "doughnuts," or shaped washers
3. Block and Tackle or other suitable holding device
4. Cutting Tools
 - a. Pliers (for cotter removal)
 - b. Grinder

This instruction is also based on using complete Sub-assemblies and not rebuilding chain by using individual components such as rollers, bushings, pins and plates.

On multiple strand chains this instruction is based upon slip fit center plates. For chains with press fit center plates, consult the manufacturer.

Since most roller chain is worn out at 3% elongation, judgment should be used comparing the value of reworking chain versus replacement with a new roller chain.

The following cautionary statement should be observed when working on the connecting or disconnecting of roller chain. This instruction applies to all techniques so described in this bulletin.

SAFETY PRECAUTIONS

Serious personal injury can result if safety rules are not followed. Observe the following safety precautions when installing a chain.

- Shut off the power to the equipment and lock out the power switches before installing chains.
- Always wear safety glasses to protect your eyes.
- Wear protective clothing, gloves, and safety shoes as appropriate.
- Support the chain to prevent uncontrolled movement of the chain or parts.
- Restrain shafts and sprockets from free rotation where such rotation could permit uncontrolled chain movement and cause personal injury or equipment damage.
- Use pressing equipment to remove or install press fit pins or link plates. Keep tooling in good condition and use it properly. If pressing equipment is not available, contact the chain manufacturer for additional guidance.
- Know and understand the chain construction, including the correct direction for pin removal and insertion, before connecting or disconnecting a chain.
- Use sub-assemblies for rework and not individual components.
- Damaged chain may be yielded and therefore should not be reworked.

**CONNECT-DISCONNECT
INSTRUCTIONS FOR
SINGLE STRAND ROLLER CHAINS**



Chain Construction

GENERAL INSTRUCTIONS

The rework of chain must utilize complete unaltered sub-assemblies of roller links and pin links of the type shown below:

PIN LINKS



Single Cotter Type



Double Cotter Type

CONNECTING LINKS



Double Cotter Type



Spring Clip Type

ROLLER LINK



CAUTION: SEE INTRODUCTION FOR INSTRUCTION

TOOLS - Bench Cutting

When connecting/disconnecting chain, pressing equipment is preferred. Also, a chain vise or a similar type of holding device is recommended to secure and support the chain in place.

Various types of chain vises and chain detachers are commercially available. See below - as shown in Figures 301, 302, and 402. Special cutting blocks can be made for special purpose applications such as shown in Figure 403.

SINGLE STRAND



Figure 301 - Chain Vise

The type of vise shown in Figure 301 utilizes a screw arrangement to open and close the jaws. It is available in two sizes; one for roller chains through 3/4" single pitch and 1-1/2" double pitch, and one for use with chains from 1" single pitch through 2-1/2" single pitch and 2" and 2-1/2" double pitch.

Chain is held securely between roller links for disassembly. Tools generally used are a chain vise or chain detacher and a hand grinder.

The detacher shown in Figure 302 is a convenient bench tool for uncoupling precision steel roller chains. It consists of two pieces; a fork and an anvil block. Detachers of the type shown are obtainable in chain pitch sizes to fit ANSI standard type roller chains.



**Figure 302
Fork & Anvil Type Repair Tool**

CHAIN BREAKER



Figure 402
Hand disassembly tool - commercially available



Figure 403
Homemade disassembly block for special applications.

RECOMMENDED DISASSEMBLY PROCEDURE FOR SINGLE STRANDS OF CHAIN DISASSEMBLED ON BENCH

1. If the chain has cotter type pin links, cotters should be removed before the pin is driven out. If the chain is of riveted type construction, grind the riveted end flush with the link plate before driving out the chain rivet pin so as not to damage or dislodge the bushing when disassembling. Lateral pressure on the joints and overheating must be avoided so that the original design integrity is maintained.
2. Place the chain in fixtures at the point to be disassembled. See Figure 601, 301, and 302. The roller link side plates should rest on the top surface of the fixture jaws so that it is held securely.
3. Press or drive out the two pins on the pin link. Be sure to apply pressure alternately on the two pins so as to avoid distortion of the roller link plates and to prevent damage to the interior of the bushings.
4. Check end roller links to ensure bushings remain fully assembled into link plates.

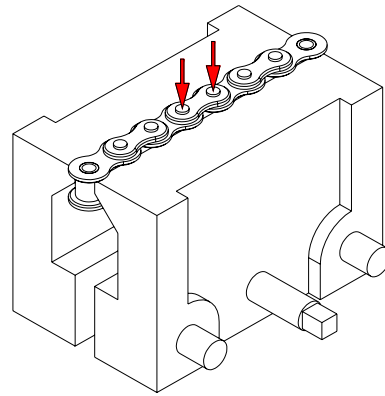

Figure 601
Illustration shows the proper procedure for mounting and holding a single strand chain for disassembly

DISCONNECT INSTRUCTIONS FOR MULTIPLE STRAND ROLLER CHAINS



Typical Chain Construction

GENERAL INSTRUCTIONS

The rework of chain must utilize complete unaltered sub-assemblies of roller links and pin links of the type shown.

ROLLER LINK CONNECTING LINK



Double Cotter Type

Spring Clip Type

RECOMMENDED DISASSEMBLY PROCEDURE FOR WORKING ON BENCH

1. If the chain is of the cotter type (see item 1 page 3 - "Procedure for Single Strands of Chain Disassembled on Bench.")
2. If the chain is of the riveted fastening type, grind off the rivet head on the link to be removed.
3. Arrange the chain on the bench, with the link to be removed over the bench edge but with the adjacent roller links supported by the bench top, or use the chain vise (Figure 901).
4. Press or drive the pins alternately drive the two pins out of the top pin link plate. Note if pins do not move out it is possible that you have press fit center plates. Consult chain manufacturer for disassembly of this type chain.
5. Use the largest diameter long-barreled punch that will pass through the center plate holes. Drive the pins out of the roller links and center plates. Be sure to stroke the pins alternately. Withdraw the punch, fold back the free roller links and remove the center plates.
6. Repeat 5 until the pins are free from all the strands of the chain.
7. If no bench is available, the chain may be placed so as to bridge the gap between any two firm supports high enough to allow the pin link to be driven out between them. The chain may also be placed on the floor with the pins horizontal. Proceed as above.

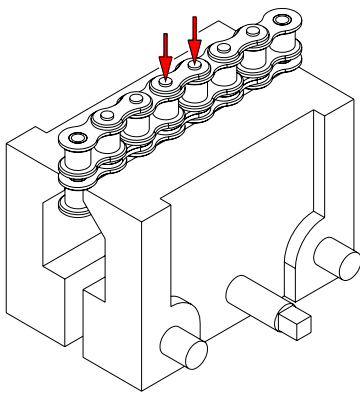

Figure 901
Illustration shows the proper procedure for mounting and holding a double strand chain for disassembly.

RECOMMENDED DISASSEMBLY PROCEDURE FOR CHAINS ON SPROCKETS.

Disconnecting chain at the sprocket is normally dependent upon accessibility. An advantage of connecting/disconnecting chain at the sprocket is that the sprocket can aid as a support. If you elect to disassemble chain at the sprocket, the following procedure must be observed:

1. A. If just removing chain, remove connecting links. If shortening chain on sprocket, follow 1B.
B. Rotate the sprocket until the link to be removed (usually the pin link adjacent to the connecting links) is engaged with the teeth on the sprocket.
2. All chain tensioning devices should be loosened.
3. The sprocket should be secured to prevent rotation.
4. Secure chain to sprockets, both sides of disconnect point, to prevent chain from falling off sprockets. The following devices may be used to secure the chain: Wire, Clamps, Tape, etc.
5. A. Riveted-type chain construction; With a portable hand grinder, remove the rivet heads on the pin link.
B. Cotter-type chain construction: Remove the fastener.
6. Press or Drive the two pins out of the pin link plate. Be sure to press or drive the pins alternately to avoid distortion of the roller link.
7. Use the largest diameter long-barreled punch that will pass through the center plate holes. Drive the pins out of the roller links and center plates. Be sure to press or drive the pins alternately. Withdraw the punch, fold back the free roller links, and remove the center plates.
8. Repeat 7 until the pins are free from all strands of the chain.

RECOMMENDED ASSEMBLY PROCEDURE FOR SINGLE STRAND CHAIN ASSEMBLED ON BENCH

A cut chain can be assembled by adding a connecting link. To assemble the chain, proceed as follows:

1. Arrange the chain on the floor or bench and insert the pins of the connecting link into the loose roller links.
2. Turn the chain over and place the free pin link plate over the pin ends.
3. Solidly support the bottom of the chain and with a hollow punch, press the link plate down to the prescribed height.
4. Cotted Construction: After the cap plate is set down insert the proper fastener.
5. After assembly, make sure that the joint flexes freely and is not tight. If joint is tight, press or drive the pin ends to create more clearance between pin link plates and roller link and free the tight joint.

RECOMMENDED ASSEMBLY PROCEDURE FOR MULTIPLE STRAND CHAIN ASSEMBLED ON BENCH.

The procedure so described is used for slip fit center plate construction. For press fit center plate construction consult with manufacturer.

A cut chain can be reassembled by adding a connecting link. To assemble the chain, proceed as follows:

1. Arrange the chain on a bench with pins vertical and insert the pins of the connecting link in the top pair of roller links. (See Figure 1501).
2. Holds the first pair of center plates in place and swing the next pair of roller links in line with the pins.
3. Press or drive the pin link or connecting link pins through the roller links and center plates, applying pressure to the pins alternately.
4. Repeat Step 3 until all the roller links are engaged.
5. Turn the chain over and place the free link plate over the pins.

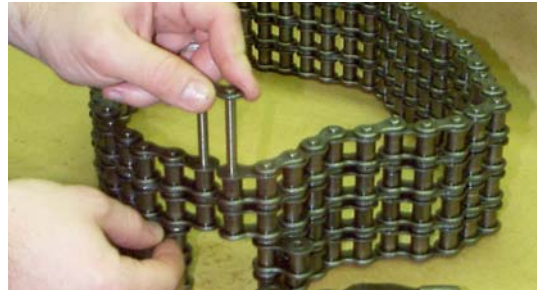

Figure 1501

6. Cotted Construction: Set the cap plate down with a hollow punch and insert the fastener.
7. After assembly, make sure that the joint flexes freely and is not tight. If joint is tight, strike the pin ends to create more clearance between pin link plates and roller link and free the tight joints.

RECOMMENDED ASSEMBLY PROCEDURE FOR SINGLE STRAND CHAIN ON SPROCKETS.

To couple the ends of a chain together:

1. Loosen the takeups to provide sufficient "working slack".
2. Bring the ends together over one sprocket, using the teeth to hold the chain. Lock the sprocket in position.
3. Insert pin or pin link to couple chain into an endless strand.
 - A. Install connecting pin plate and fastener.
4. Adjust takeups to provide proper tension for operation.
5. When it is necessary to couple chain in the span between sprockets draw the ends together with a block and tackle or with other equipment that will bring ends together. Then proceed as in Steps 3 and 4 above.

RECOMMENDED ASSEMBLY PROCEDURE FOR MULTIPLE STRAND CHAINS ON SPROCKETS

This is based on slip fit center plate construction. For press fit center plate construction consult manufacturer. Note: For large pitch multiple strand chain on long center distances, the following procedure may not be feasible. In this case, consult a chain manufacturer.

1. When sprockets and shafts have been lined up and all other preparations complete, block both shafts to prevent rotation. Then place the chain over the sprockets so that the chain wraps the driven sprocket and overlaps the driver sprocket (usually the smaller sprocket) and secure chain to the driver sprocket.
2. Grasp the end of the chain which overlaps the driver sprocket and unblock the driver sprocket so it is free to rotate.
3. Pull the chain toward the driven sprocket until the ends come together on the driven sprocket (usually the larger sprocket)
 - A. Reblock sprockets.
4. Insert the connecting link through the roller links and center plates.
5. Place the connecting plate over the pin ends and insert the cotters (or attach the spring clip).



American Chain Association
6724 Lone Oak Boulevard
Naples, Florida 34109
PH: 239/514-3441 FAX: 239/514-3470
www.americanchainassn.org