

Connect and Disconnect Instructions for Engineered Steel and Cast Chains

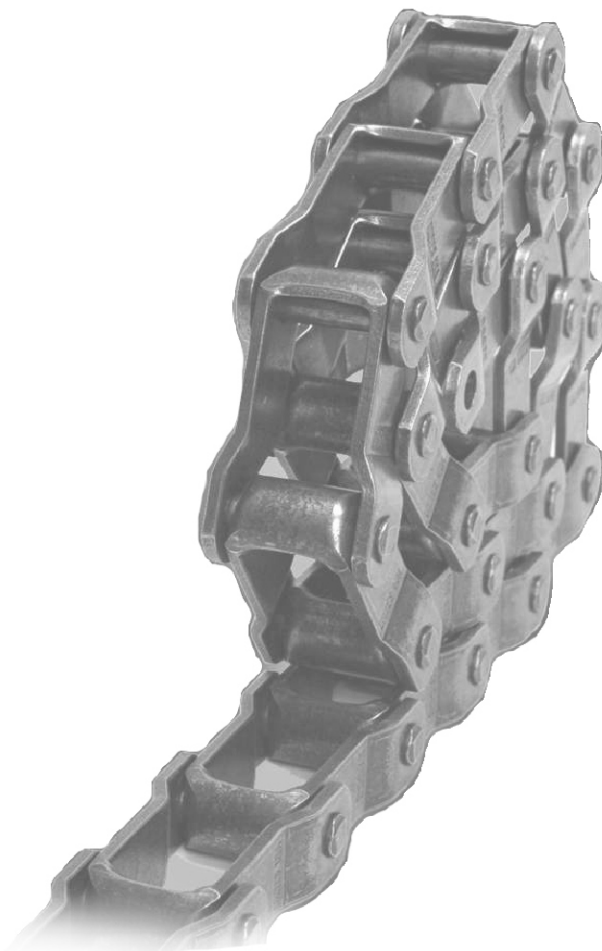

INTRODUCTION to CONNECT AND DISCONNECT INSTRUCTIONS for ENGINEERED STEEL AND CAST CHAINS

CONTENTS

General Instructions	3	Connect: One Chain Pin/Rivet.....	4
Tools and Equipment	3	Disconnect: One Chain Pin/Rivet	5
Avoid Damaging Chain Components	3	Connect: One Sidebar	6
Caution/Safety Statement	3	Disconnect: One Sidebar.....	7

PURPOSE

The purpose of these Chain Connect-Disconnect Instructions is to provide the chain user with recommended methods for assembling and disassembling chain.

IDENTIFICATION OF CHAIN BY SIDEBAR TYPE AND PIN STYLE

Many types of chains are manufactured in which links are connected using many styles of pins, rivets, or connecting links. A method is presented whereby proper assembly or disassembly requires identification only of the sidebar type and pin style, regardless of manufacturer.

OFFSET SIDEBAR OR STRAIGHT SIDEBAR CHAIN

Most chains can be divided into two basic types: (1) Offset Sidebar and (2) Straight Sidebar. Offset sidebar chains have links connected by pins or rivets. Straight sidebar chains may be roller links, block links or bar links connected by connector links, consisting of two sidebars and two pins or rivets.

Both lateral position of the sidebars and the prevention of rotation of the pins in the sidebars are accomplished by various design features such as pin head locks, controlled press fits, flats, shoulder or multiple diameters. A particular chain may use one or a combination of these methods of pin securement.

ANSI B29-LISTED CHAINS/ BASIC PROCEDURES

This instruction applies to catalog-listed Engineered Steel and Cast Chains utilizing different pin shapes. Because the method of chain support and other factors are common to many of these pin shapes, two basic procedures to connect-disconnect cover all of the Engineered Steel and Cast Chains.

FORMAT AND CONTENT OF CONNECT-DISCONNECT

Each of the two instructions is self-explanatory and contains the following information:

Title:

Types of Chain and Construction Sketches

To Connect:

Pin Orientation
Chain Support
Application of Force
Cottering or Riveting

To Disconnect:

Disconnect Location
Chain Support
Cotter or Rivet Removal
Application of Force

GENERAL INSTRUCTIONS

The repair of chains must be limited to the repair or replacement of complete links or sections. All other modifications, alterations or repairs must be authorized by the manufacturer.

Before connecting / disconnecting chain:

1. Loosen **all** tensioning devices in order to provide working slack.
2. Safely secure respective sprockets to prevent rotation.

3. Connect / disconnect, loose chain sections on a bench, table, or floor whenever possible.
4. When connecting / disconnecting chain into/out of the conveyor or drive system, it is generally advantageous to work at the sprockets as the sprockets can aid as a support. However, accessibility will quite often determine whether the connect / disconnect point should be at the sprocket or at some location away from the sprocket.

TOOLS AND EQUIPMENT

Tools and equipment should be properly sized to insure safe working conditions and to reduce the possibility of damage to the chain or its components. When connecting/disconnecting chain, pressing equipment is preferred. Also, a chain vice or a similar type of holding device or clamps are recommended to secure and support the chain in place. Please contact the Manufacturer for specific instructions if necessary.

The following are commonly used tools in connecting / disconnecting chain.

1. Pressing Equipment
 - a. Hydraulic chain press
 - b. Jack (mechanical or hydraulic)
 - c. Arbor press
2. Support Fixtures
 - a. Chain vice
 - b. "C" clamps
 - c. Parallel bar spacers, "doughnuts," or shaped washers
3. Block and Tackle or other suitable holding device
4. Cutting Tools
 - a. Pliers (for cotter removal)
 - b. Grinder
 - c. Hacksaw

AVOID DAMAGING CHAIN COMPONENTS

When repairing, replacing a section, or adding a section to existing chain, extreme care must be exercised to prevent damage to the remaining components of the chain. This damage can lead to premature failure of the chain. A few examples are:

1. Using cutting torches for removal of cotters or rivet ends could damage the sidebar.
2. Excessive heating of a rivet end for riveting could damage both sidebar and rivet.

3. Careless and excessive grinding in removing rivet heads could damage the chain sidebar.
4. Improper support of chain or improperly applied force can damage pins and/or sidebars.

When reconnecting the chain, new pins, rivets or connecting links must be used. Adjacent links must not be coupled to badly worn links . . . rather, the entire chain must be replaced to prevent premature failure.

Chains listed as ANSI Standard have control dimensions to assure intercoupleability of links produced by different manufacturers. The standards do not cover interchangeability of parts. Therefore it is imperative that mating parts (pins and sidebars), used in connecting the chain, be made by the same manufacturer of the specific chain.

CAUTION

Warning Safety Statement

BEFORE starting the installation, repair, or replacement, PLEASE READ and FOLLOW THE SAFETY INSTRUCTIONS LISTED BELOW.

CAUTION

Serious personal injury can result if safety rules are not followed. Observe the following safety precautions when connecting and disconnecting chain:

- Shut off power to the equipment and lock out the power switches before installing chains.
- Always wear safety glasses to protect your eyes.
- Wear protective clothing, gloves and safety shoes as appropriate.
- Support the chain to prevent uncontrolled movement of the chain or parts.
- Restrain shafts and sprockets from free rotation where such rotation could permit uncontrolled chain movement and cause personal injury or equipment damage.
- Use pressing equipment to remove or install press fit pins or link plates. Keep tooling in good condition and use it properly. If pressing equipment is not available, contact the chain manufacturer for additional guidance.
- Know and understand the chain construction, including the correct direction for pin removal and insertion, before connecting or disconnecting a chain.

TO CONNECT CHAIN BY MEANS OF ONE CHAIN PIN/RIVET

Applies to offset chains and straight sidebar chains where it is possible or desirable to assemble the pin/rivet from one side.

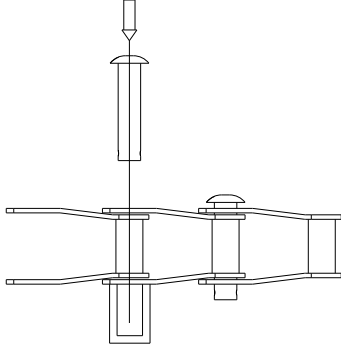

- Heavy Duty Offset Sidebar Power
 Transmission Roller Chains.....ANSI B29.10
 "H" Type Mill Chains.....ANSI B29.14
 Welded Steel Type Mill Chains.....ANSI B29.16
 Welded Steel Type Drag Chains....ANSI B29.18
 700 Class Chains.....ANSI B29.21M

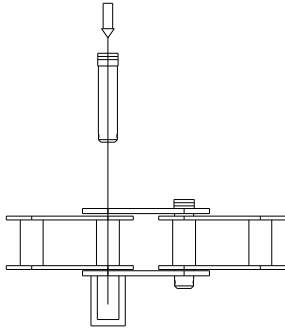

- Combination Chains.....ANSI B29.11
 Steel Bushed Rollerless Chain.....ANSI B29.12
 Heavy Duty Roller Type
 Conveyor Chains.....ANSI B29.15

1. Draw ends of chain together so that the pin holes and barrel or bushing I.D. in the mating link are aligned.
2. Insert the chain pin or rivet through the mating links. Align the mechanical lock if so designed.
3. Support the opposite side of the chain so that there is enough space below for complete insertion of the chain pin or rivet.
4. Press or drive the chain pin or rivet into place.
5. Assemble cotter in chain pin or rivet over the end of the chain rivet to form a head.
6. Check for free articulation of the chain joint.

TYPICAL PINS AND RIVETS

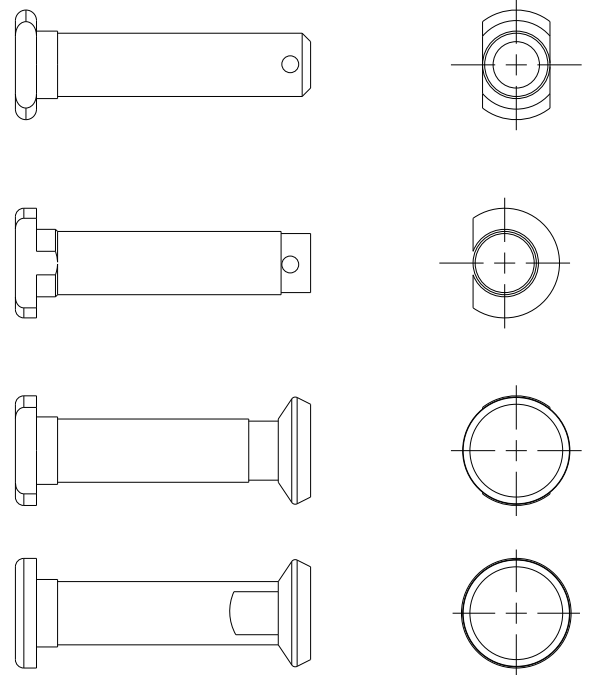
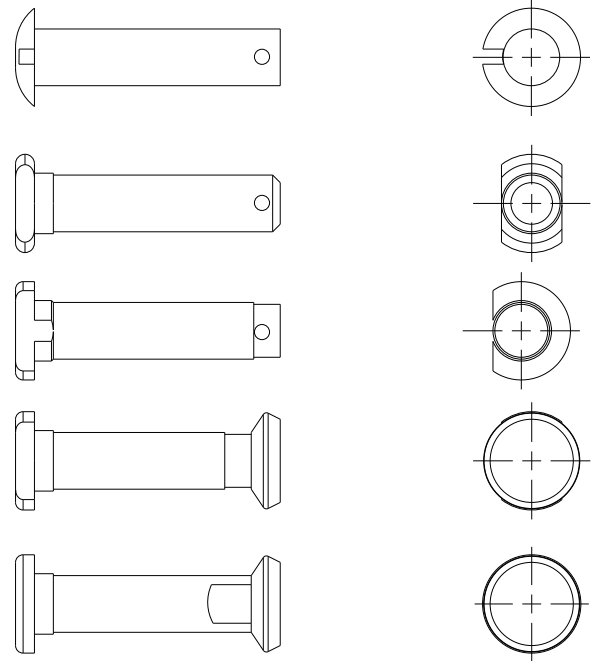

TO DISCONNECT CHAIN BY MEANS OF ONE CHAIN PIN/RIVET

Applies to offset chains and straight sidebar chains where it is possible or desirable to disassemble the pin/rivet from one side.

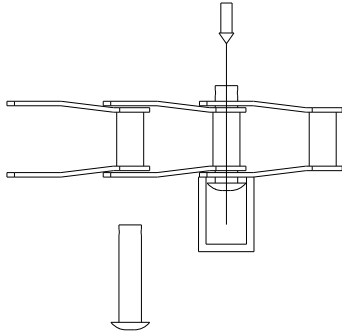

Heavy Duty Offset Sidebar Power
Transmission Roller Chains.....ANSI B29.10
“H” Type Mill Chains.....ANSI B29.14
Welded Steel Type Mill Chains.....ANSI B29.16
Welded Steel Type Drag Chains....ANSI B29.18
700 Class Chains.....ANSI B29.21M

TYPICAL PINS AND RIVETS

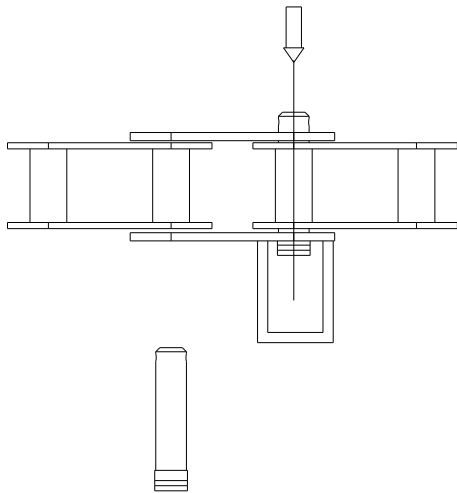
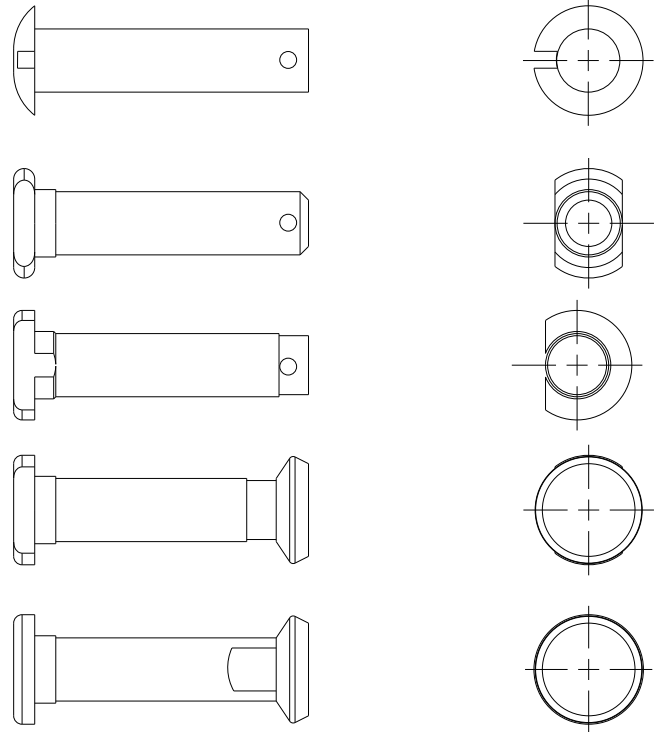

Combination Chains.....ANSI B29.11
Steel Bushed Rollerless Chain.....ANSI B29.12
Heavy Duty Roller Type
Conveyor Chains.....ANSI B29.15

1. Remove cotter from the chain pin or grind riveted head of chain rivet flush with the sidebar.
2. Support the opposite side of the chain so that there is enough space below for complete removal of the chain pin or rivet.
3. Press or drive chain pin or rivet free from the chain.

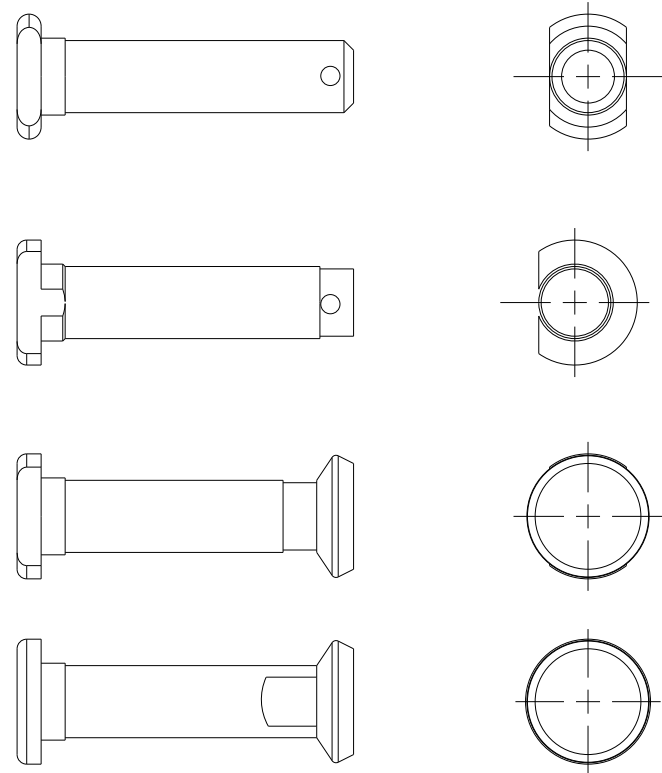

TO CONNECT CHAIN BY MEANS OF ONE SIDEBAR

Applies to straight sidebar chains where it is impossible or undesirable to assemble the pin/ rivet from one side.

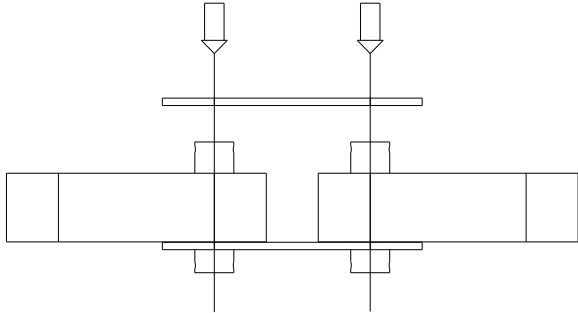

Bar Link Chain.....No Current ANSI Std.

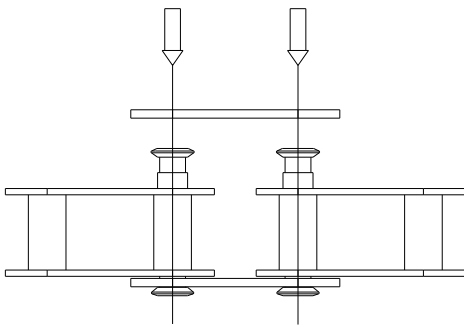

Steel Bushed Rollerless Chain.....ANSI B29.12
Heavy Duty Roller Type
Conveyor Chains.....ANSI B29.15

1. Assemble two chain pins or rivets into one sidebar or use partially assembled outside link.
2. Place each end of chain to be connected over its corresponding chain pin or rivet of the partially assembled outside link.
3. Place the second sidebar of the outside link over the protruding chain pins or rivets.
4. Press the second sidebar uniformly onto the chain pins or rivets, or alternately and squarely strike each end of the sidebar until it is in place.
5. Assemble cotter in chain pin or rivet over the end of the chain rivet to form a head.
6. Check for free articulation of the chain joints.

TYPICAL PINS AND RIVETS

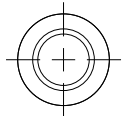
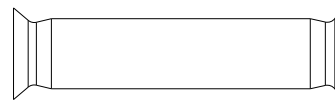
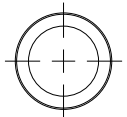
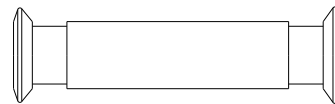
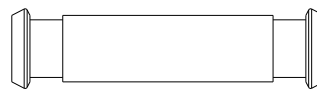
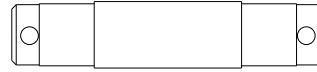

TO DISCONNECT CHAIN BY MEANS OF ONE SIDEBAR

Applies to straight sidebar chains where it is impossible or undesirable to disassemble the pin/ rivet from one side.

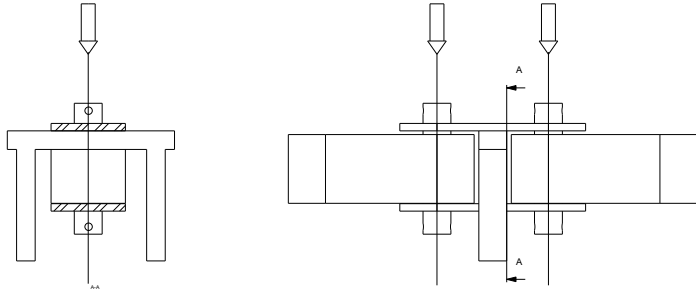

Bar Link Chain.....No Current ANSI Std.

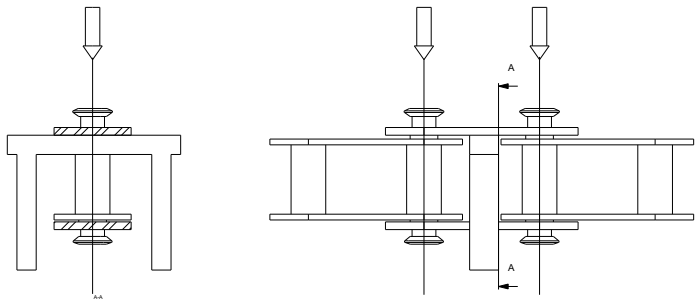

Steel Bushed Rollerless Chain.....ANSI B29.12
 Heavy Duty Roller Type
 Conveyor Chains.....ANSI B29.15

1. Remove cotters from both chain pins of an outside link or grind rivet heads of both chain rivets of an outside link flush with the sidebar.
2. Support the top sidebar of the outside link so that there is enough space below for complete removal of both chain pins or rivets from the top sidebar.
3. Press or drive the ends of the chain pins or rivets simultaneously or alternately and squarely free from the top sidebar.

TYPICAL PINS AND RIVETS

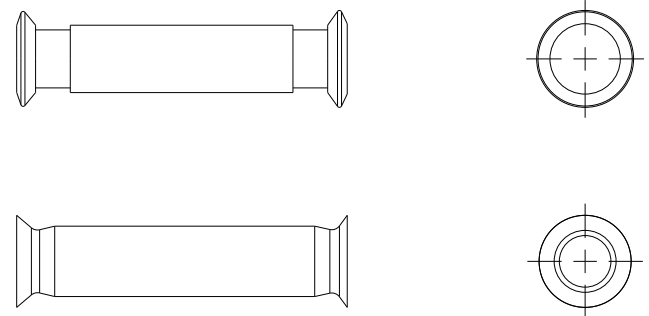
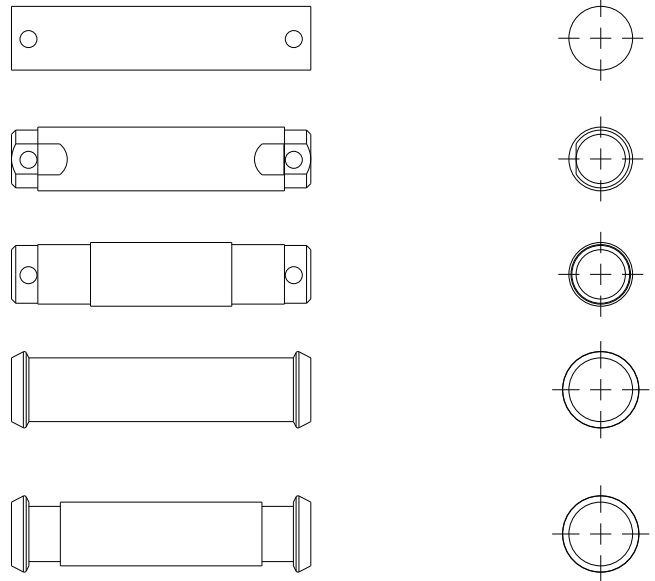



American Chain Association
6724 Lone Oak Boulevard
Naples, Florida 34109
PH: 239/514-3441 FAX: 239/514-3470
www.americanchainassn.org